











Date Revised:	March 2021	Overall Task Risk Rating:	Before Controls	A	After Controls	B
Description:	Situations where a worker may be exposed to a fall hazard (i.e. working near excavations / trenches, operating power elevated work platforms, performing maintenance activities at the Asphalt Plant, etc....)					
Location(s):	Shop, Asphalt Plant & Construction Projects					
Associated Documents: Equipment and Machinery Operation WTS, Power Elevating Work Platforms WTS, Scaffolding WTS, Trenching and Excavating WTS						

RED FLAGS (HOLD WORK UNTIL CORRECTED):

Note:

- If a worker does not hold a valid Ministry of Labour Working at Heights training card (Valid for 3 years), do not commence work
- If any piece of fall protection equipment is damaged or defective must be replaced prior to work being undertaken

PERSONAL PROTECTIVE EQUIPMENT (CSA APPROVED)

									
Head Protection	Foot Protection	High-Vis Protection	Hearing Protection	Hand Protection	Eye Protection	Respiratory Protection	Skin Protection	Face Protection	Fall Protection
<input checked="" type="checkbox"/>	<input checked="" type="checkbox"/>	<input checked="" type="checkbox"/>	<input type="checkbox"/>	<input type="checkbox"/>	<input type="checkbox"/>	<input type="checkbox"/>	<input type="checkbox"/>	<input type="checkbox"/>	<input checked="" type="checkbox"/>

Note:

- Fall Protection PPE falls under Gazzola Pavings "Specialized PPE" - Foreman and Superintendents can speak to H&S Coordinators to ensure sufficient specialized PPE is available for the task

SAFE WORK PRACTICES (SWP)

General Working at Heights Practices:

- Start the work only when you are certain that you understand the work, the hazards and you have implemented the appropriate controls
- Unsafe conditions and situations must be reported to Foreman/Superintendents immediately (and stop work until the hazard is controlled)
- All employees working at heights must use fall protection if they are exposed to following hazards:
 1. Falling more than 3 meters (10ft)
 2. Falling more than 1.2 meters (4ft) if the work area is used as a path for a wheelbarrow or similar equipment
 3. Falling into operating machinery
 4. Falling into water or another liquid
 5. Falling into or onto a hazardous substance or object
 6. Falling through an opening on a work surface
 7. If a worker is exposed to a fall of 2.4 meters (8ft) or more from the any of the following work surfaces:
 - The surface of a bridge
 - A floor, (i.e. the floor of a mezzanine or balcony)
 - A roof while formwork is in place
 - A scaffold or other work platform, runway or ramp
- Horizontal lifelines shall be designed by a professional engineer and must be installed by a competent person
- All lanyards will be arranged so that the worker will not hit the ground if they fall
- Any temporary anchor point being used must meet the requirements of the Regulations
- Any piece of fall protection equipment involved in a fall must be immediately taken out of service and replaced
- Lifelines may run vertically or horizontally (installed between two or more anchors), depending on the application
- Horizontal systems must be engineered properly, due to the loading applied to the anchors

Surface Opening Protection / Guardrails / Floor Coverings:

- Surface openings must be protected by a guardrail system or secured wood or metal covers

- If work must be undertaken near unprotected openings, workers must wear full body harnesses and lifelines secured to a proper anchor
- Refer to the Working at Heights WTS for more information

Guardrails:

- Consists of a top rail, mid-rail, and toe board intended to stop a worker from inadvertently stepping off a working level and falling
- Guardrail components and capability to resist loads must meet legislation
- Where there is a danger of materials or objects falling from the work surface to a working level below, a toe-board is required
- Posts are not to exceed a maximum spacing of 2.4 metres (8 feet) apart
- Prior to and during the installation of a guardrail system, it is essential that workers who may go near the open edge and may be exposed to the risk of falling a distance exceeding 2.4 metres (8 feet) have Working at Heights training and proper fall protection equipment

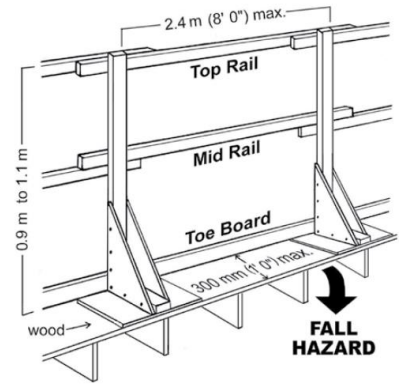

Travel Restraint:

- A travel restraint system is intended to limit a worker's movement so the worker is unable to reach a location where there is a risk of falling
- A travel restraint system could consist of a safety harness, lanyard, rope Grab, and an adequate anchor point (or other variations)
- The system must be adjusted so the fully extended lifeline and lanyard prevents the worker from reaching a point where they may fall

Fall Arrest Systems:

- A fall arrest system reduces the potential for injury when a fall takes place by arresting or stopping the fall
- A fall arrest system consists of an anchor point, shock absorbing lanyard, and a full body harness

Fall Rescue Plan Requirements:

- A written plan must be available onsite
- Suitable anchor points to be used for the rescue equipment
- A method to attach the fallen worker to the rescue system
- The direction that the fallen worker needs to be moved to get them to the point of safety (raising, lowering or lateral)
- The potential first aid needs of the fallen worker

Environmental Considerations:

- If the anchor is exposed to the weather elements, it must be corrosion resistant

Inspections:

- Workers shall visually inspect their fall arrest equipment before use each day
- Any piece of fall protection equipment that is damaged or defective must be replaced prior to work being undertaken
- Annual inspection of harness and equipment is to be completed and documented

Training:

- Employee Orientations (including roles, responsibilities, applicable workplace task standards, WHMIS, etc.)
- Workers exposed to fall hazards, must be trained in 'Working at Heights' by an MOL approved training provider
- All workers who have to wear fall protection must be trained in its use
-

Personal Protective Equipment:

- Workers on construction projects must wear, at a minimum, head, foot and high visibility protection. Eye protection when necessary
- A CSA approved full body harnesses and shock absorbing lanyard, must be worn at heights of 10 feet (or more), unless properly protected (by scaffolding, guardrails or floor covers, that are installed appropriately)



JOB HAZARD AND RISK ANALYSIS		RISK RATING SYSTEM	
TASK HAZARDS	RATING BEFORE CONTROLS	TASK CONTROLS	RATING AFTER CONTROLS
• Improper Training	B	• Workers must have 'Working at Heights' training from an MOL approved training provided	C
• Lack of equipment Inspections	B	• A daily visual inspection of all Working at Heights PPE must be completed prior to beginning the task	C
• Inadequate Fall Protection	A	• A complete fall protection system must be used at any time a worker is in danger of falling	B
• Improper use of Travel Restraint	A	• Ensure the travel restraint system restrains a worker from approaching the fall hazard or an unprotected edge	B
• Lack of Rescue Plan	B	• A written Rescue Plan is mandatory whenever a fall arrest system is used, prior to starting work	C
• Falls, Lack of PPE	A	• A CSA approved full body harnesses and shock absorbing lanyard, must be worn at heights of 10 feet (or more), unless properly protected (by scaffolding, guardrails or floor covers	B
• Improper Equipment Usage	A	• Ensure workers tie-off to appropriate anchor points	C
• Protective Equipment Not Installed	A	• Ensure guardrails are installed appropriately	B
• Lack of Inspection	A	• Workers shall visually inspect their fall arrest equipment before use each day • PPE must not be used if any defects are identified - inform your superintendent / foreman	C
• Lack of Planning	A	• Ensure Fall Rescue Plan developed when fall protection and fall arrest measures used	C
• Rescue Equipment Not Available	B	• Ensure equipment required by the Fall Rescue Plan, is available and not used for any other purpose, on-site	C

SAFE JOB PROCEDURES (SJP)

- Pre-Task Commencement:**
1. Gather and wear the required PPE for the task - on construction sites, all must wear head, foot and high visibility protection. Eye protection when necessary
 2. A CSA approved full body harnesses and shock absorbing lanyard, must be worn at heights of 10 feet (or more), unless properly protected (by scaffolding, guardrails or floor covers, that are installed appropriately)
 3. Ensure the site-specific workplace violence assessment is complete
 4. Complete the Daily GAZZ Card and review with workers the shift's tasks with any associated, potential fall hazards and control strategies
 5. Ensure all workers understand the GAZZ Card contents, and sign off in acknowledgement
 6. Ensure controls are in place prior to commencing work so risks are mitigated / eliminated
 7. Determine what equipment / machinery / tools and material, are required for the completion of the task
 8. Inspect all equipment / machinery / tools prior to use and document the inspections on appropriate forms when required
 9. Ensure preventative maintenance activities have been completed where required, prior to using equipment / machinery / tools
 10. If equipment / machinery / tools are observed to be damaged, remove it from use and notify the Foreman / Superintendent
 11. Install fencing, hoarding and guardrails where needed
 12. Locate utilities – Call "Ontario One Call" for locate services (when necessary)
 13. Develop a Fall Protection and Rescue Plan that incorporates the following controls, listed in order of priority: a guardrail or protective cover, a travel restraint system, a fall restriction system, a fall arrest system
 14. Ensure all workers who will be working at heights, have received 'Working at Heights' training, from a MOL approved training provider

During Task:

1. The installation of guardrails around openings will only be completed by trained workers utilizing fall protection when necessary
2. Fall protection must be used at all times while in powered elevated work platforms
3. Ensure workers are tied off to appropriate anchor points
4. Ensure that guardrails or floor coverings removed to complete a task, are reinstalled immediately thereafter
5. Operate equipment machinery and/or tools as per manufacturer's instructions

Fall Rescue:

1. Call 911
2. Inform your Foreman / Superintendent
3. Assess the situation
4. Identify proper position from which to carry out the operation
5. Identify proper anchor points
6. Identify a point of safety to move the fallen worker to
7. Make sure all involved are aware of the procedure to be carried out and their role within it
8. Ensure personnel have been trained in rescue procedures and are competent to carry out their role
9. Carry out the rescue steadily and in a controlled manner
10. Make sure communication is maintained at all times
11. Monitor the injured person's condition at all times and where possible provide the necessary first aid
12. Conduct a review of the whole situation identifying areas of improvement for the future

Task Completion:

1. Ensure all Fall Protection Equipment is kept in appropriate condition for future use
2. Ensure all equipment / machinery / tools are maintained and stored appropriately in the designated locations
3. Implement any housekeeping or maintenance as required